

Pricing of Bandwidth and Communication on Demand Services



Jean Walrand

<http://www.eecs.berkeley.edu/~wlr>

EECS
U.C. Berkeley

BoD2008
Salvador
Brazil

Issues



- **Bandwidth** is a finite divisible resource.
- Users **compete** for that resource and value it differently.
- Providing end-to-end bandwidth requires a **combination of links** that belong to different operators.
- Communication services differ in **quality**.
- **Signaling** between users and providers cannot be exceedingly complex.
- **Who** should pay? End users or providers or both?

Pricing of Bandwidth and Communication on Demand Services



- Issues
- Users & Providers
- General Pricing
- Externality: Congestion Pricing
- Service Differentiation: Paris Metro Pricing
- Competition of Providers
- Pricing QoS
- Uncertainty
- One-Sided Auctions
- Net Neutrality
- References

Pricing of Bandwidth and Communication on Demand Services



- Issues
- Users & Providers ←
- General Pricing
- Externality: Congestion Pricing
- Service Differentiation: Paris Metro Pricing
- Competition of Providers
- Pricing QoS
- Uncertainty
- One-Sided Auctions
- Net Neutrality
- References

Users & Providers

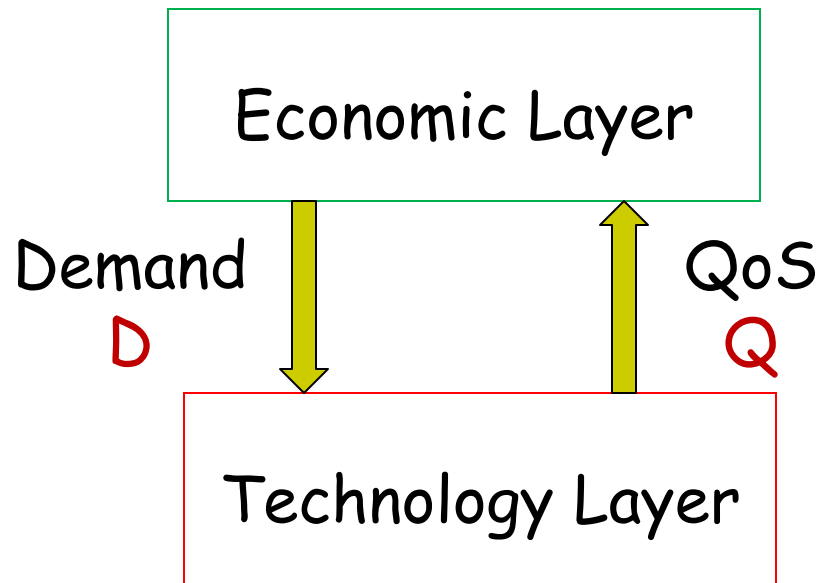
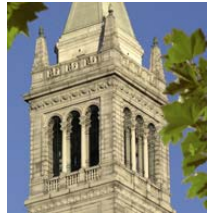

Users & Providers

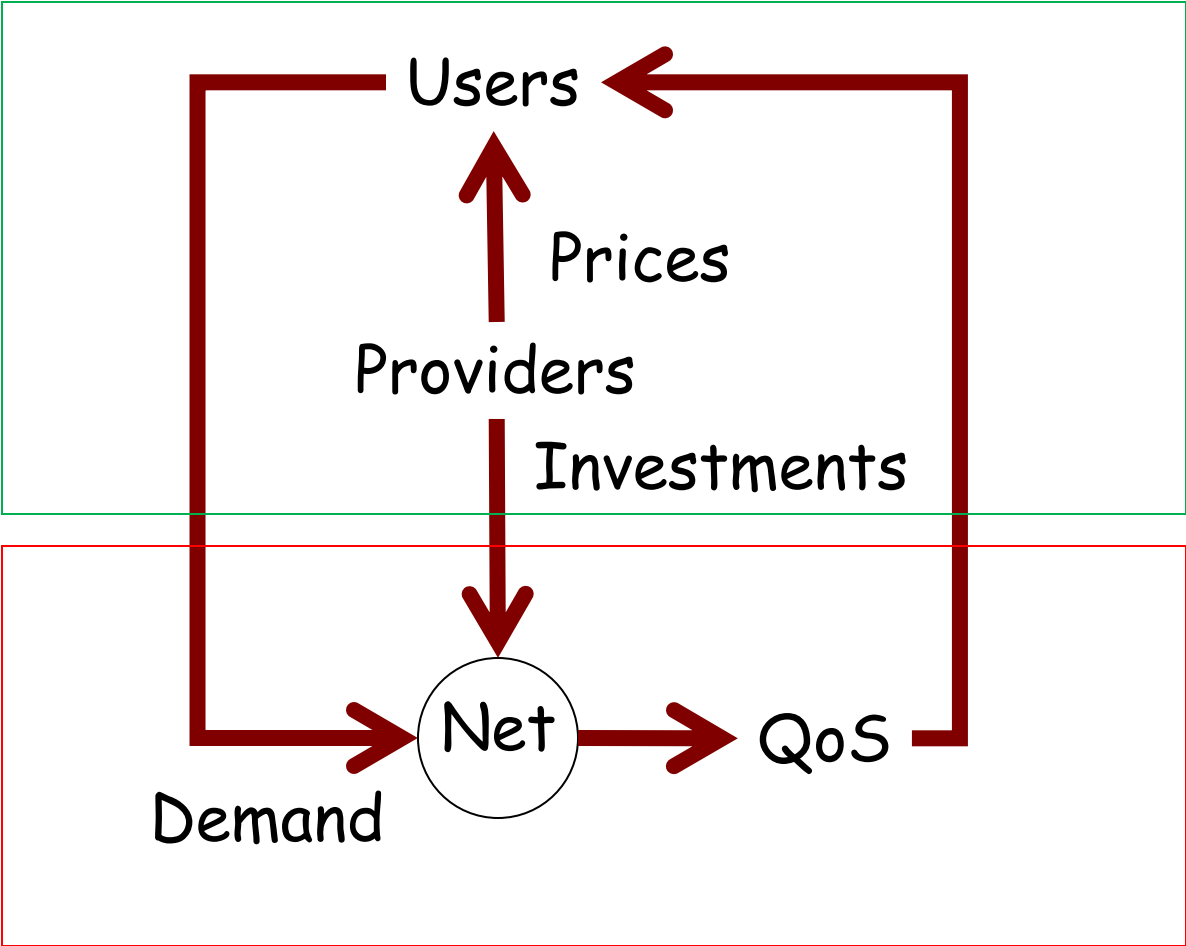
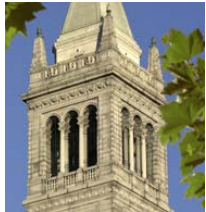

Economic Layer

Technology Layer

Users & Providers

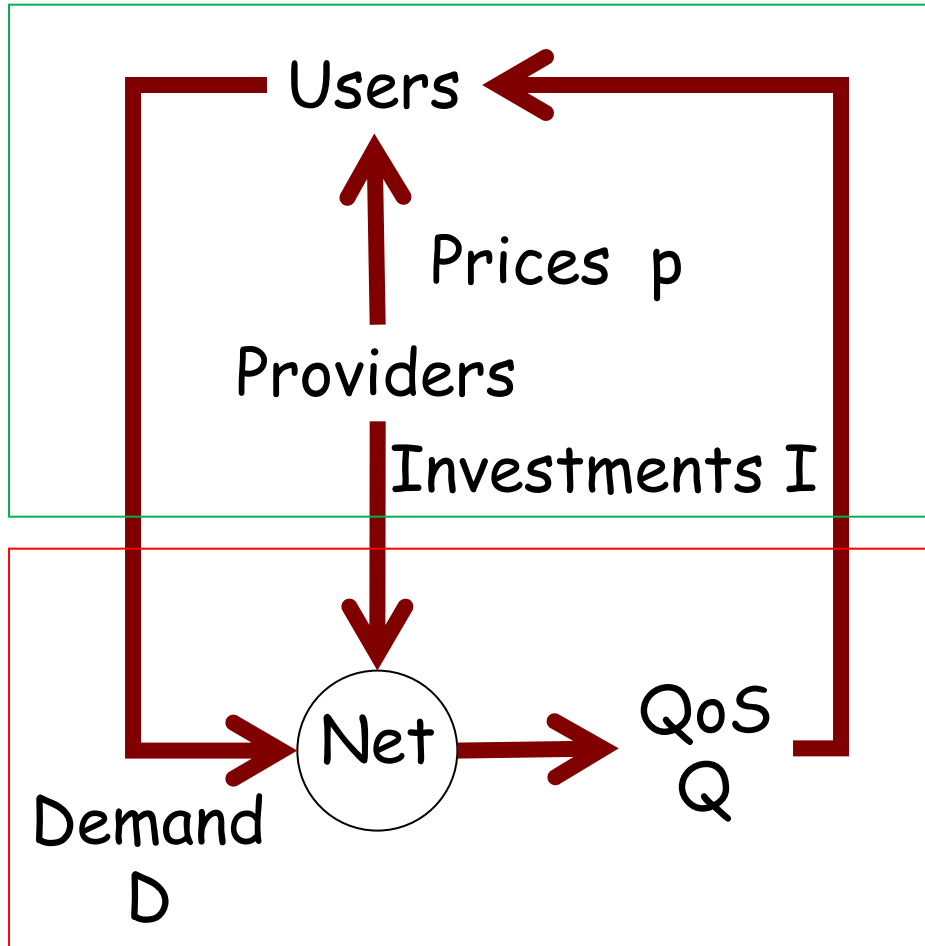

$$D = \operatorname{argmax} U(D, Q, p)$$

$$(p, I) = \operatorname{argmax} \{p \cdot D - \alpha I\}$$

$$Q = Q(D, I)$$

Note: Protocol choice is another important element

Users & Providers



Strategic Behavior:

Users:

Usage of services: which network, when, how, ...

P2P: What to make available?

Modify "technology": cheat protocol, bigger antenna, ←??

Providers:

Prices

Capacity

Content (more, new, ...)

New technology (WiMax, metro Wi-Fi, 3G, QoS, Vcast, ...)

Users & Providers



General Observations:

Users and Providers interact in a network



In general,

Selfish optimal \neq Social optimal (price of anarchy)

- Selfish users over-consume
- Selfish providers over-price, under-invest



“Internalize the externality”

- Congestion pricing
- Revenue-sharing agreement

Pricing of Bandwidth and Communication on Demand Services

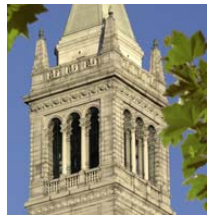

- Issues
- Users & Providers
- General Pricing ←
- Externality: Congestion Pricing
- Service Differentiation: Paris Metro Pricing
- Competition of Providers
- Pricing QoS
- Uncertainty
- One-Sided Auctions
- Net Neutrality
- References

General Pricing



This is the simplest idea: $\text{Max } pD(p)$

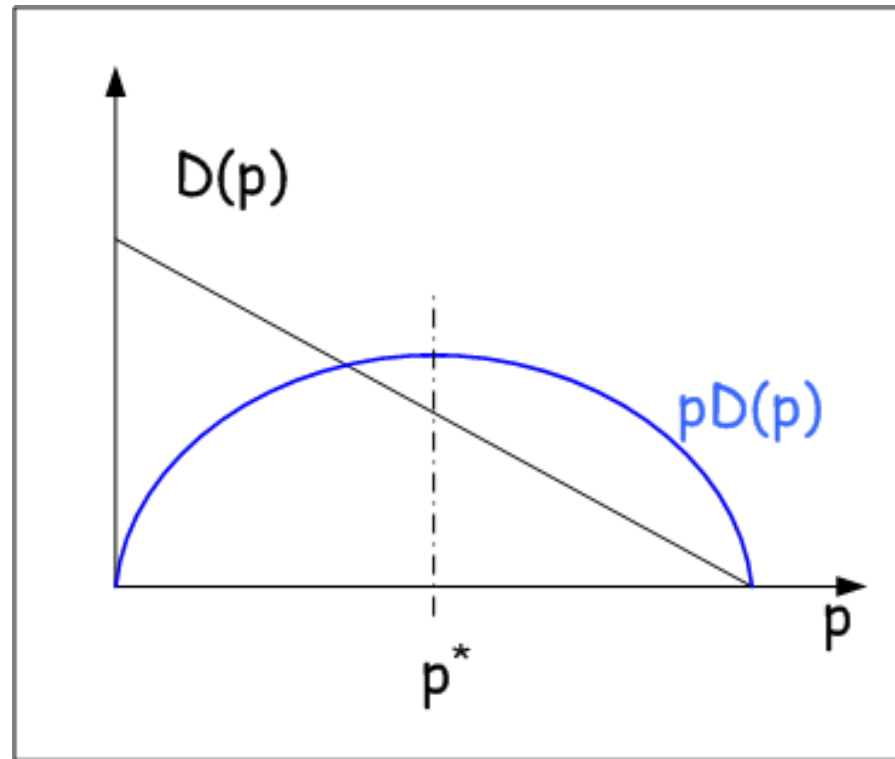

More complete: $\text{Max } pD(p) - C(D(p))$

Pricing of Bandwidth and Communication on Demand Services



- Issues
- Users & Providers
- General Pricing
- Externality: Congestion Pricing ←
- Service Differentiation: Paris Metro Pricing
- Competition of Providers
- Pricing QoS
- Uncertainty
- One-Sided Auctions
- Net Neutrality
- References

Externality: Congestion Pricing



In fact, D depends on Q and Q depends on D

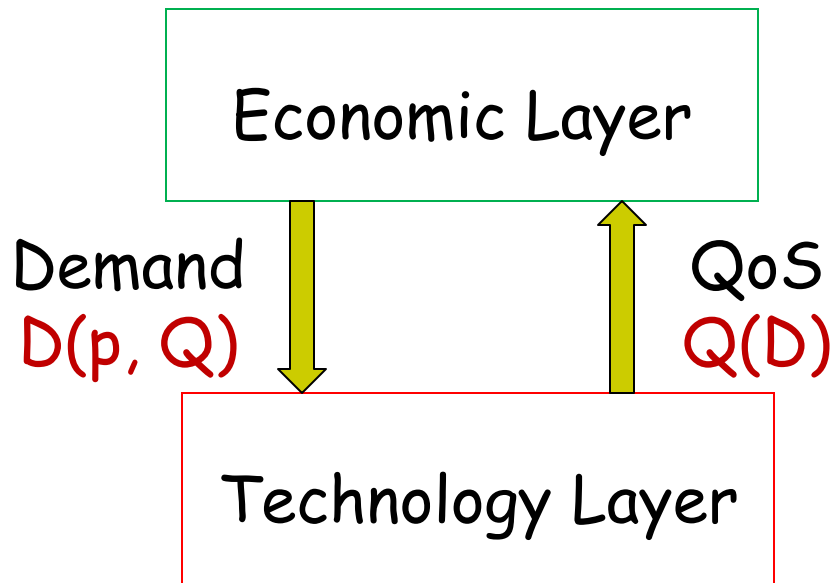

The actions of one user affect other users:
externality.

Externality: Congestion Pricing



Assume N users share a network.

User i chooses his activity level \tilde{x} to maximize

$$U(x_i) - [x_1 + \dots + x_N]$$

where the sum is the congestion disutility.

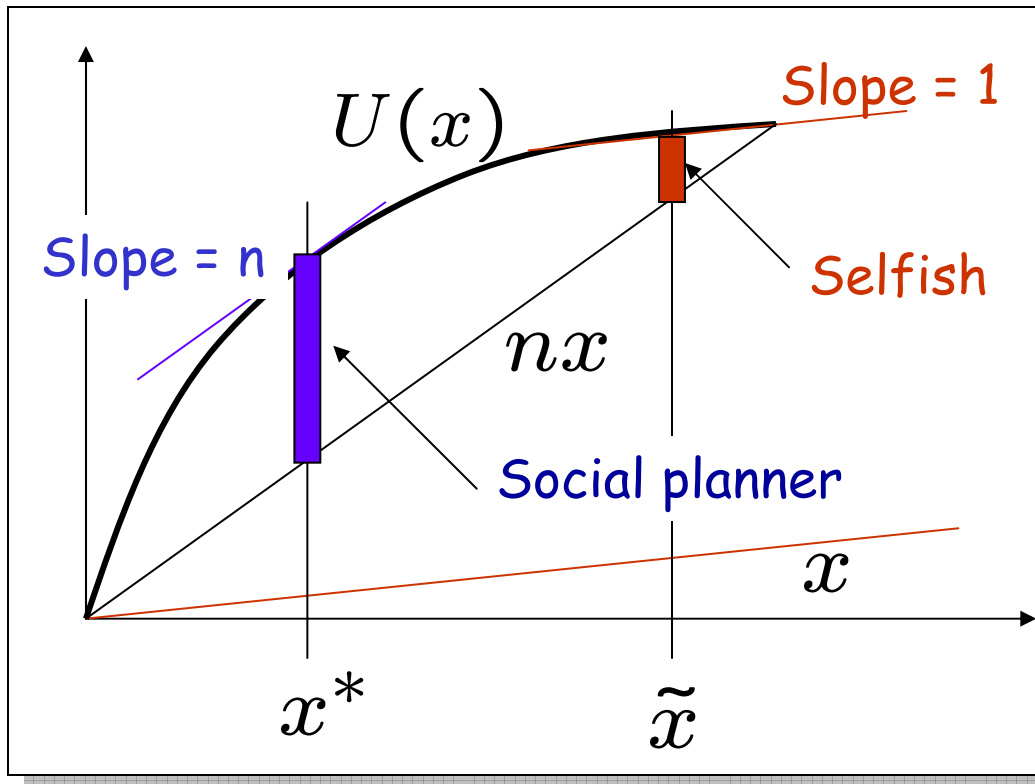
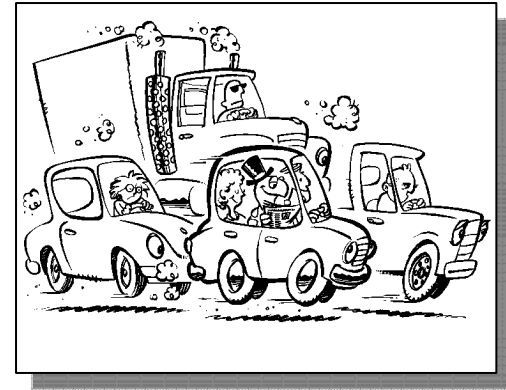

A social planner chooses the common activity level $x_i = x^*$ to maximize $U(x) - Nx$.

**Selfish users over-consume:
They neglect their impact
on others.**



Externality: Congestion Pricing

Assume congestion price: $p = (N - 1)x$.

User i chooses his activity level to maximize $U(x_i) - [x_1 + \dots + x_N] - (N - 1)x_i$.

Now, user i chooses the socially optimal x .

The congestion price is the cost imposed by each user on all the other users.

The activity x_i of user i imposes a congestion cost x_i on each of the $N - 1$ other users. The total "externality" cost is $(N - 1)x_i$.

When users face their externality cost, their selfish behaviour is socially optimal.

Pricing of Bandwidth and Communication on Demand Services



- Issues
- Users & Providers
- General Pricing
- Externality: Congestion Pricing
- Service Differentiation: Paris Metro Pricing ←
- Competition of Providers
- Pricing QoS
- Uncertainty
- One-Sided Auctions
- Net Neutrality
- References

Service Differentiation: Paris Metro Pricing

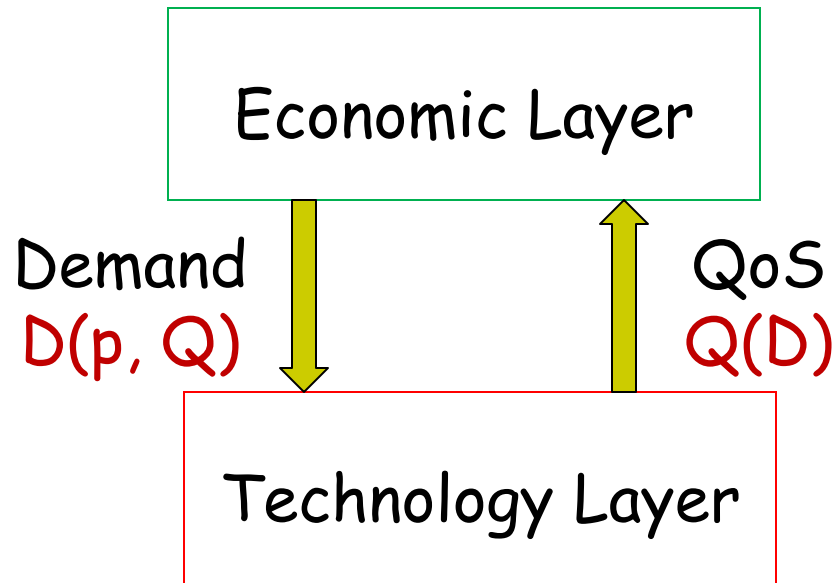

In fact, services require a different QoS:

$$D_i(p, Q), i = 1, 2, \dots$$

Service Differentiation: Paris Metro Pricing

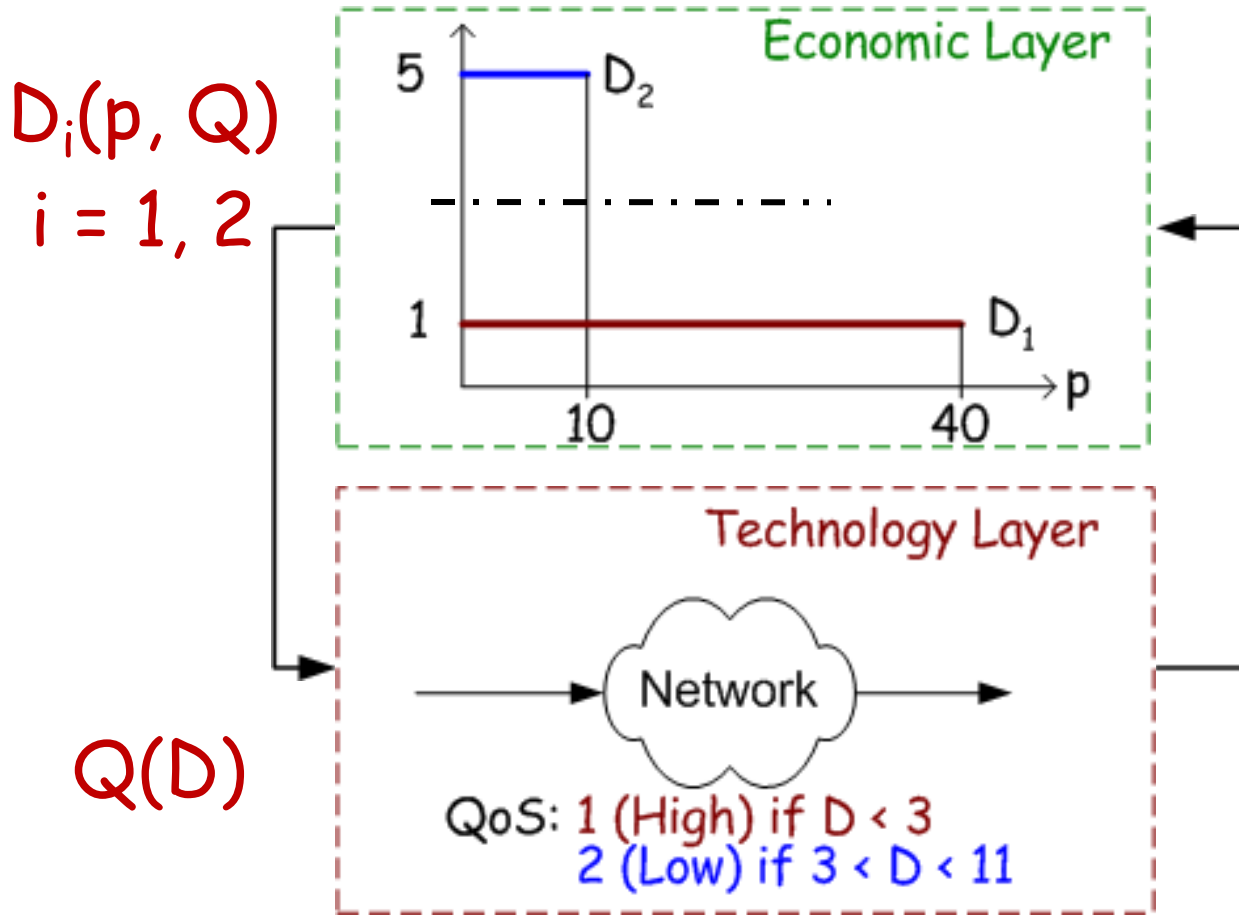

$p \rightarrow D_1, D_2$
 \rightarrow Revenue

Question:
How to price?

Service Differentiation: Paris Metro Pricing



Solution 1:

$$p = 10 \rightarrow D_2$$

$$\rightarrow \text{Revenue} = 5 \times 10$$

(Note: $p = 40 \rightarrow D_1 \rightarrow 1 \times 40$)

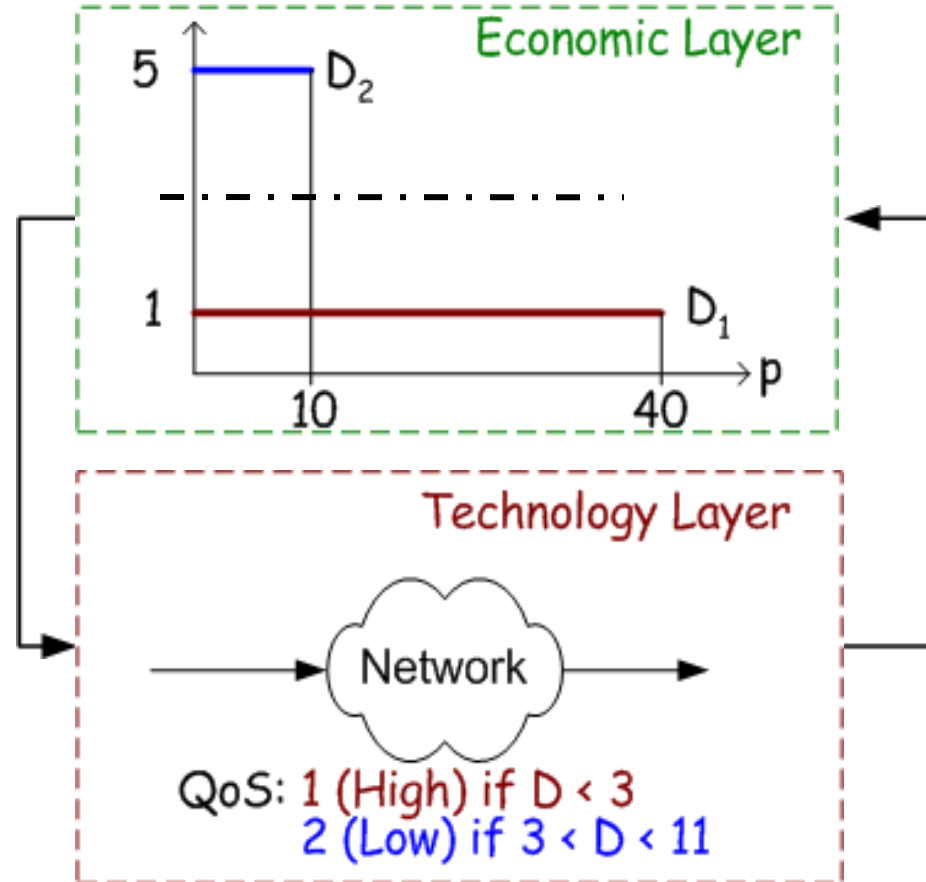

Service Differentiation: Paris Metro Pricing

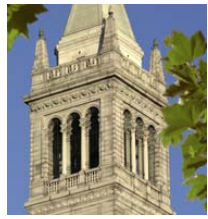

Solution 2:

$p_1 = 40 \rightarrow D_1$
 $\rightarrow \text{Revenue} = 1 \times 40$

$p_2 = 10 \rightarrow D_2$
 $\rightarrow \text{Revenue} = 5 \times 10$

Total Revenue: 90

Note: QoS achieved
by pricing
(not by QoS mechanisms)

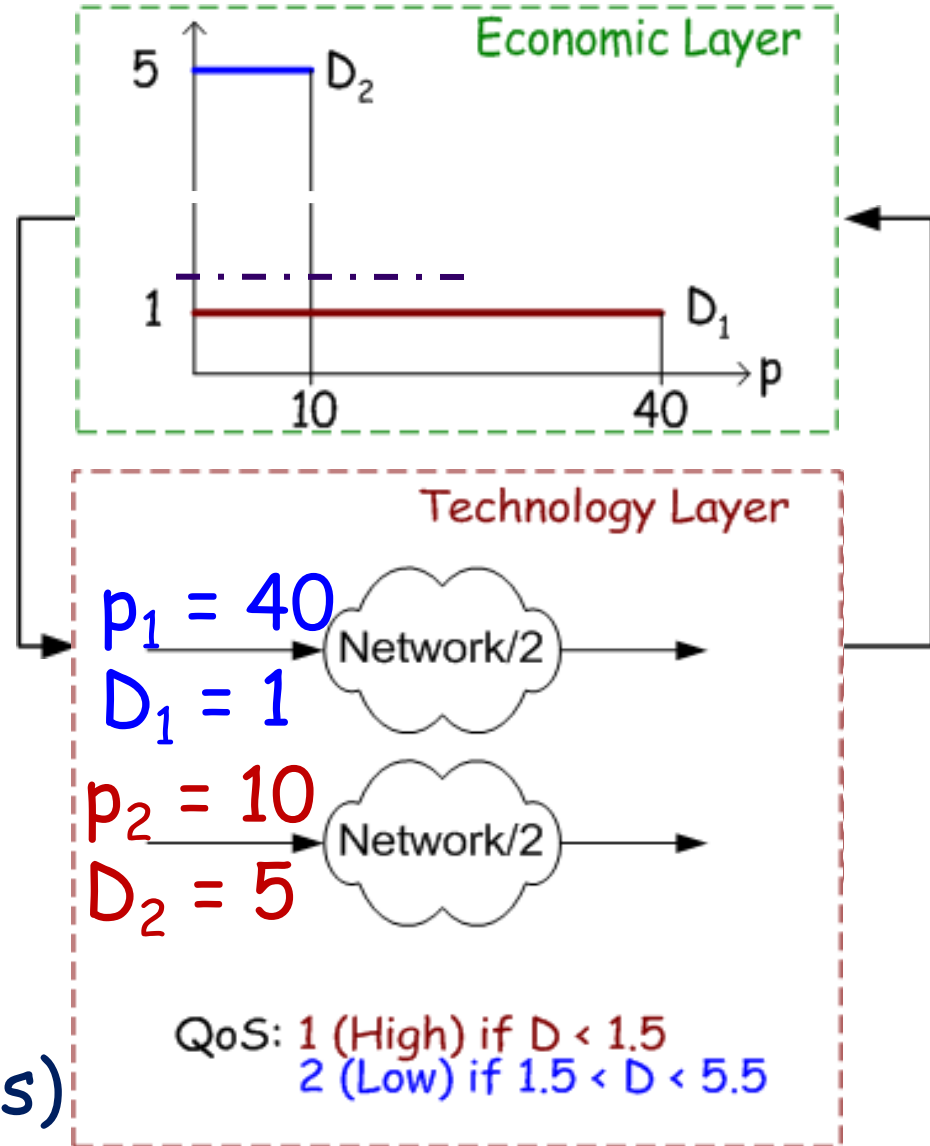

Pricing of Bandwidth and Communication on Demand Services

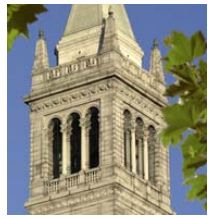

- Issues
- Users & Providers
- General Pricing
- Externality: Congestion Pricing
- Service Differentiation: Paris Metro Pricing
- Competition of Providers ←
- Pricing QoS
- Uncertainty
- One-Sided Auctions
- Net Neutrality
- References

Competition of Providers



Question:

Will providers
"specialize"
with $D_1 \rightarrow$ Prov. A
 $D_2 \rightarrow$ Prov. B

Intuition: No

D_2 brings more revenue
than D_1
 \rightarrow Providers may
compete for it

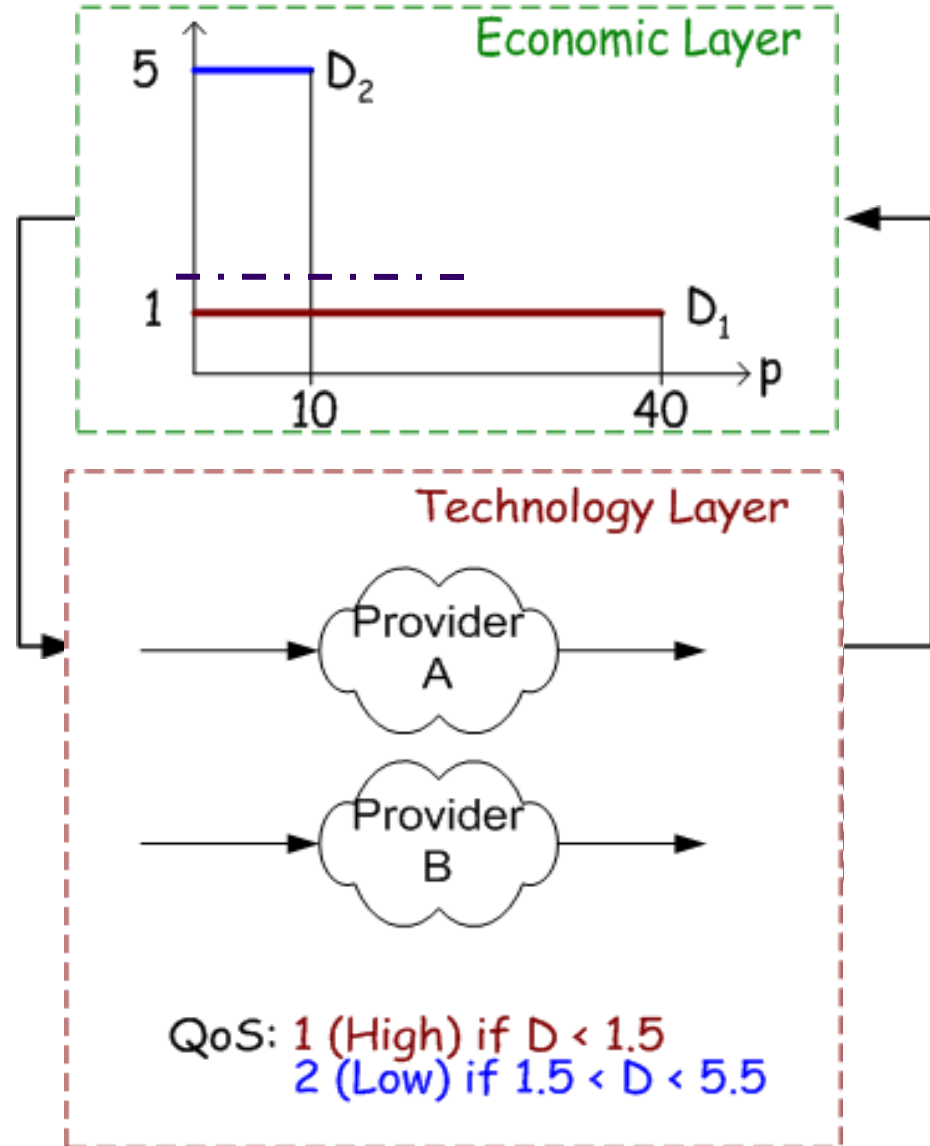



Competition of Providers

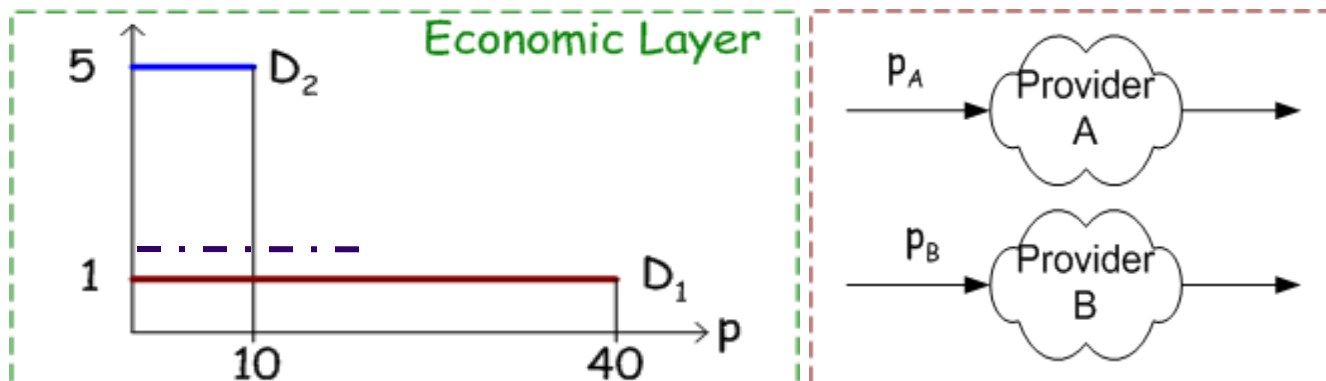

Best Response of A to p_B : (Assume prices must be integers)

Assume $p_B = p$ in $\{0, 1, \dots, 10\}$

If $p_A = p$, then $R_A = 5p/2$

If $p_A = p - 1$, then $R_A = 5(p - 1)$

If $p_A = 40$, then $R_A = 40$

→ Best response is $p_A = 40$ if $p < 9$
 $p - 1$ if $p = 9$ or 10



Competition of Providers

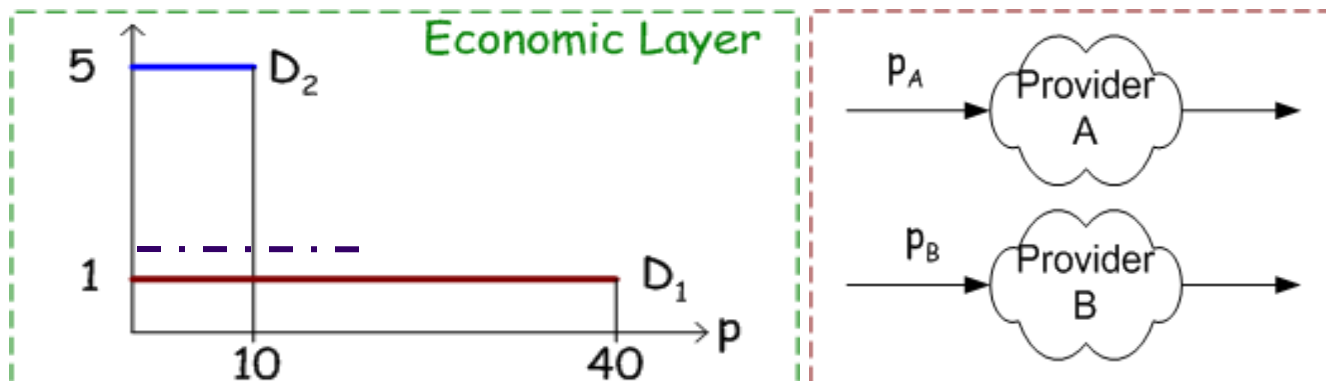

Best Response of A to p_B : (continued)

Assume $p_B = p$ in $\{11, 12, \dots, 40\}$

→ Best response is $p_A = 10$

Competition of Providers



Best Responses: (continued)

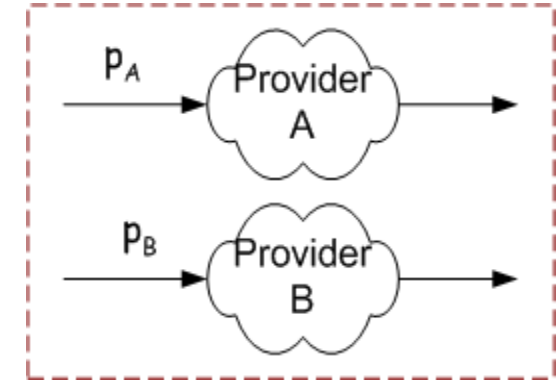

No Nash Equilibrium

p_A 10 8 10 ...

p_B 40 9 40 9

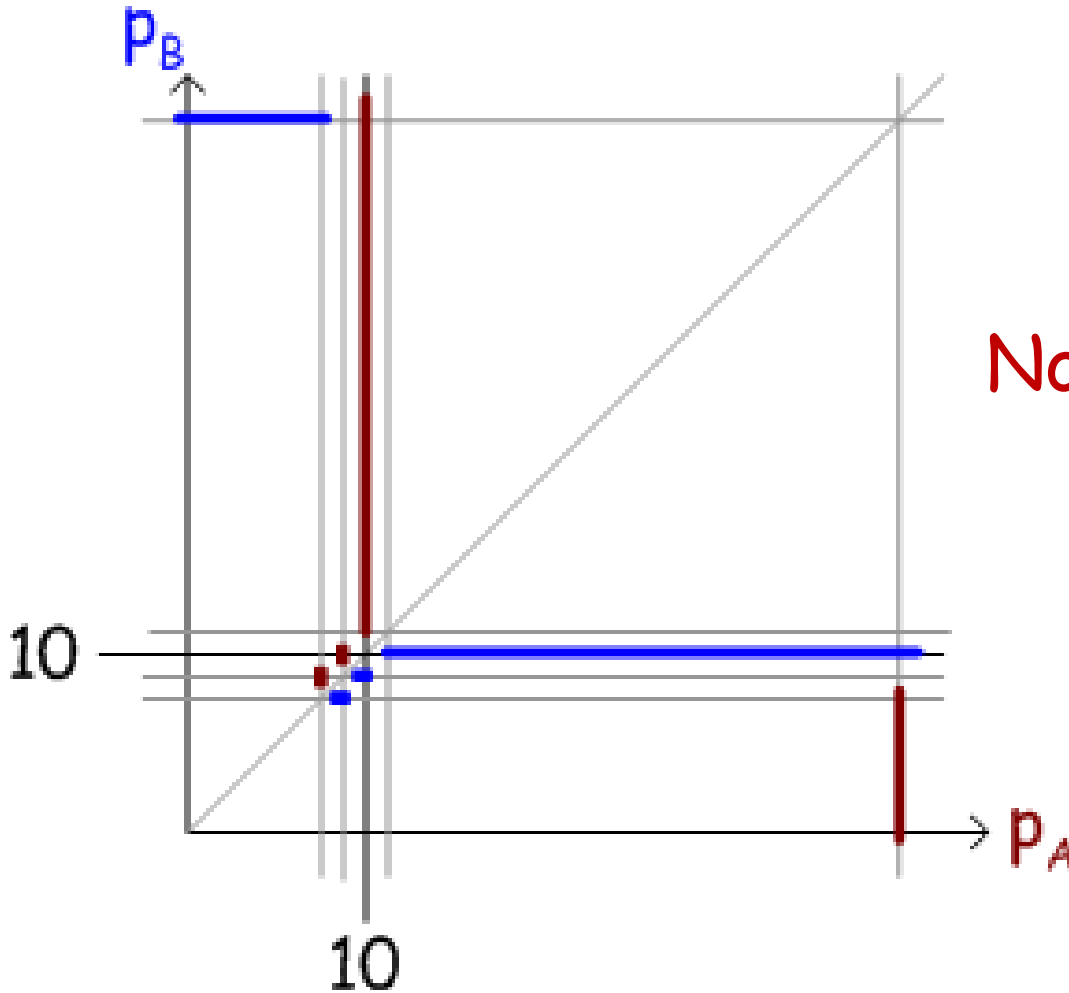



Competition of Providers

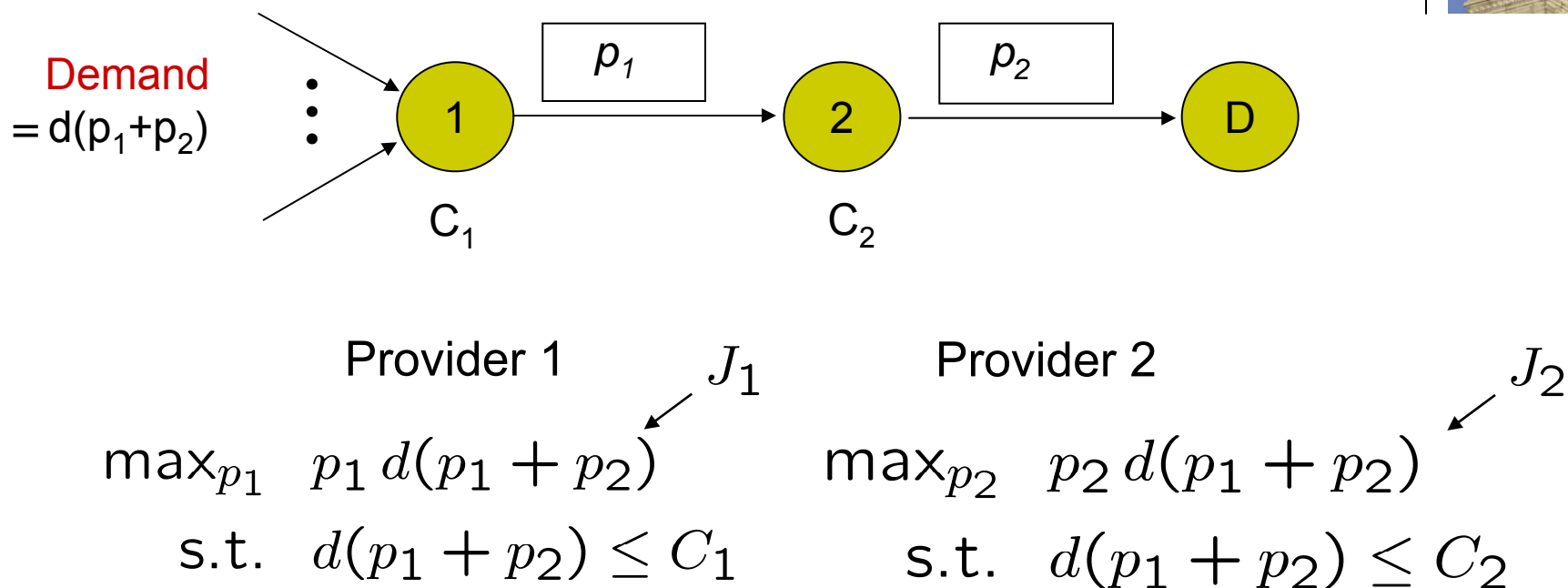

- A game between two providers
- Different solution concepts may apply, depend on actual implementation
- First we consider a **Nash game**

Competition of Providers



Analysis of Nash game shows:

1. Bottleneck providers get more share of revenue than others
2. Bottleneck providers may not have incentive to upgrade
3. Efficiency decreases quickly as network size gets larger (revenues/provider drop with size)

Competition of Providers



Revenue Sharing Game:

Providers agree to share the revenue equally,
but still choose their prices independently

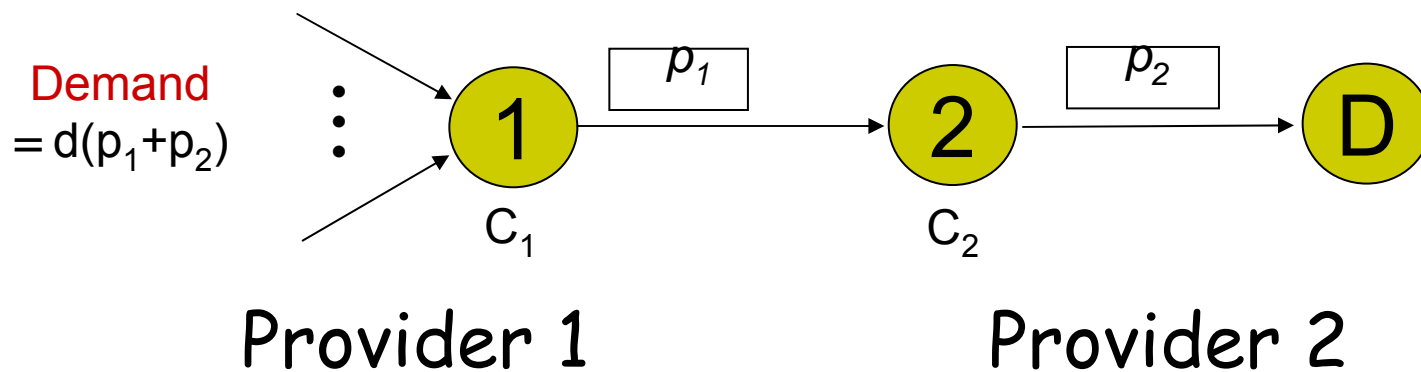

$$\begin{aligned} \max_{p_1} \quad & \frac{1}{2}(p_1 + p_2) d(p_1 + p_2) \\ \text{s.t.} \quad & d(p_1 + p_2) \leq C_1 \end{aligned}$$

$$\begin{aligned} \max_{p_2} \quad & \frac{1}{2}(p_1 + p_2) d(p_1 + p_2) \\ \text{s.t.} \quad & d(p_1 + p_2) \leq C_2 \end{aligned}$$

Competition of Providers



In this revenue-sharing game,

- A Nash Equilibrium always exists
- Incentive to upgrade
 - Upgrade will always increase bottleneck providers' revenue
- Efficient when capacities are adequate
 - It is the same as that in centralized allocation
 - Revenue per provider strictly dominates that in Nash game
- A distributed algorithm exists to compute prices.

Pricing of Bandwidth and Communication on Demand Services



- Issues
- Users & Providers
- General Pricing
- Externality: Congestion Pricing
- Service Differentiation: Paris Metro Pricing
- Competition of Providers
- Pricing QoS ←
- Uncertainty
- One-Sided Auctions
- Net Neutrality
- References

Pricing QoS

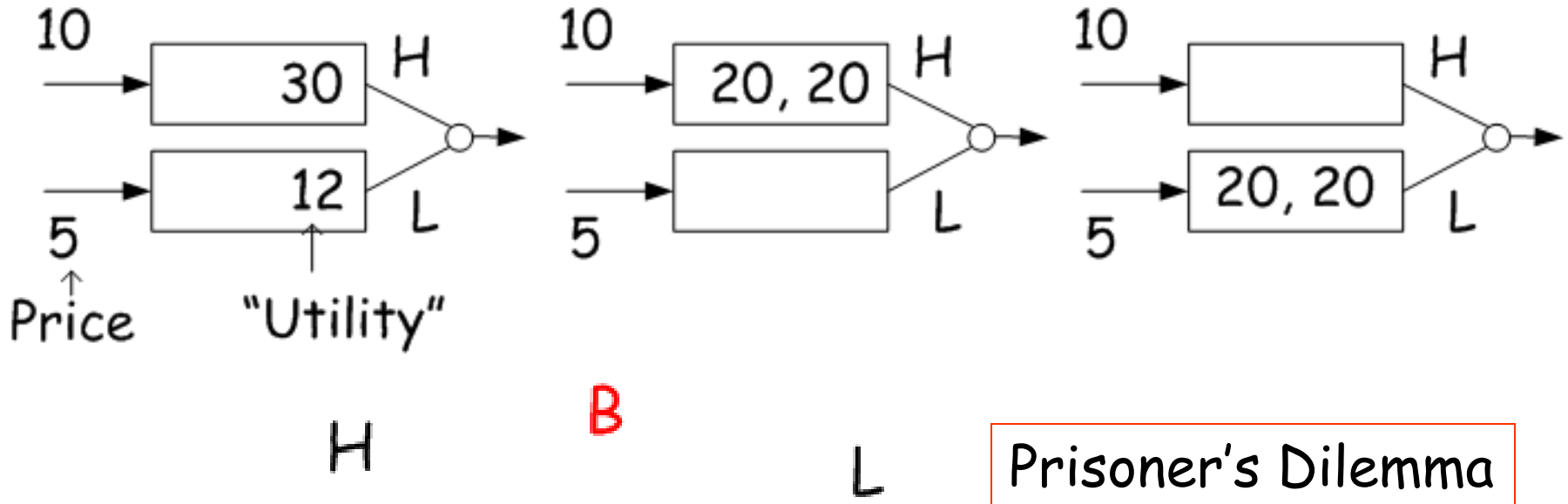

Prisoner's Dilemma

	H	$20 - 10 = 10$ $20 - 10 = 10$	$30 - 10 = 20$ $12 - 5 = 7$
A	L	$12 - 5 = 7$ $30 - 10 = 20$	$20 - 5 = 15$ $20 - 5 = 15$

Pricing of Bandwidth and Communication on Demand Services



- Issues
- Users & Providers
- General Pricing
- Externality: Congestion Pricing
- Service Differentiation: Paris Metro Pricing
- Competition of Providers
- Pricing QoS
- Uncertainty ←
- One-Sided Auctions
- Net Neutrality
- References

Uncertainty



Uncertainty may cause missing markets

Market for Lemons

Dealer buy used car for θ uniform in $[0, 1]$.

Buyer values a car that costs θ at 1.5θ .

Dealer asks X for a given used car.

Given X , potential buyer thinks that

θ is uniformly distributed in $[0, X]$.

The expected value of the car to the potential buyer is

$$E[1.5\theta|X] = 1.5 \times 0.5X = 0.75X < X.$$

Hence, the potential buyer does not buy.

If θ were known to the potential buyer, the dealer could ask 1.25θ and both the dealer and the buyer would be happy with the trade.

Pricing of Bandwidth and Communication on Demand Services



- Issues
- Users & Providers
- General Pricing
- Externality: Congestion Pricing
- Service Differentiation: Paris Metro Pricing
- Competition of Providers
- Pricing QoS
- Uncertainty
- One-Sided Auctions ←
- Net Neutrality
- References

Auction – Vickrey



One item. N buyers with valuations v_i .

- Item goes to highest bidder
- Winner pays second highest bid.

Dominant strategy: (Vickrey)
Bid true valuation (\Rightarrow efficient).

Buyer 1's reward is

$$(v_1 - z)1\{b_1 > z\}$$

where z is the second highest bid.

Note that $(v_1 - z)1\{v_1 > z\} \geq (v_1 - z)1\{b_1 > z\}$,
as you see by looking at $v_1 > z$ and $v_1 < z$.

Auction - VCG



Scheme: There is a set S of items. User i has a real utility $v_i(A)$ and declares a utility $b_i(A)$ for every subset $A \subset S$, for $i = 1, \dots, n$. The auctioneer solves **Maximize** $\sum_{i=1}^n b_i(A_i)$ over the possible partitions $(A_1, \dots, A_n, A_{n+1})$ of S . The optimum determines the allocations A_i . To calculate the payments, repeat without agent i and find the optimum allocations B_j^i . The payment of agent i is then

$$\pi_i = \sum_{j \neq i} [b_j(B_j^i) - b_j(A_j)].$$

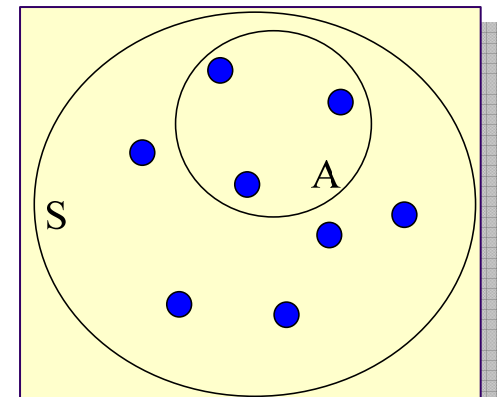

Auction - VCG



The payment of agent i :

$$\pi_i = \sum_{j \neq i} [b_j(B_j^i) - b_j(A_j)].$$

(Externality Price)

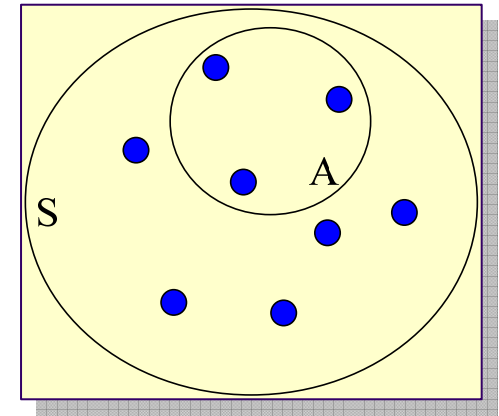

Theorem:

A dominant strategy is to declare the true valuations. The resulting NE is efficient since it maximizes the social welfare.

Auction – Bidding for QoS



Model (Shu, Varaiya)

Utility of i in class c : $v_i g_c$ ($g_c = \text{goodput}$)

True valuations:

$\{v_1, \dots, v_N\}$

Actual bids:

$\{x_1, \dots, x_N\}$



Assignments and prices:

$\{p_1, \dots, p_N\}$

g_c
↓

0,9	10	$c = 1$
0,7	10	$c = 2$
0,4	10	$c = 3$
0,2	∞	$c = 4$



Max. # connections

Auction – Bidding for QoS



VCG:

Rank in decreasing order of x_i

Fill up classes 1, 2, ... in that order

Price = reduction of value imposed on others

Say $x_1 \geq x_2 \geq \dots \geq x_{35}$

1, ..., 10	0.9	10
11, ..., 20	0.7	10
21, ..., 30	0.4	10
31, ..., 35	0.2	∞

What is p_{13} ?

13 pushes 21 and 31 down

$$\Rightarrow p_{13} = (0.4 - 0.2)x_{31} + (0.7 - 0.4)x_{21}$$

Pricing of Bandwidth and Communication on Demand Services

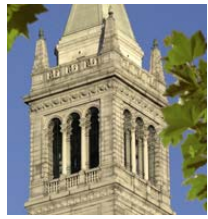

- Issues
- Users & Providers
- General Pricing
- Externality: Congestion Pricing
- Service Differentiation: Paris Metro Pricing
- Competition of Providers
- Pricing QoS
- Uncertainty
- One-Sided Auctions
- Net Neutrality ←
- References

Neutrality: Issues



- Contentious Debate



- But, what (if any) bearing should the issues have on the future network architecture?
- Does future architecture need features for
 - Revenue sharing between content and transit providers?

Neutrality: Issues



Content Provider A

Content Provider B

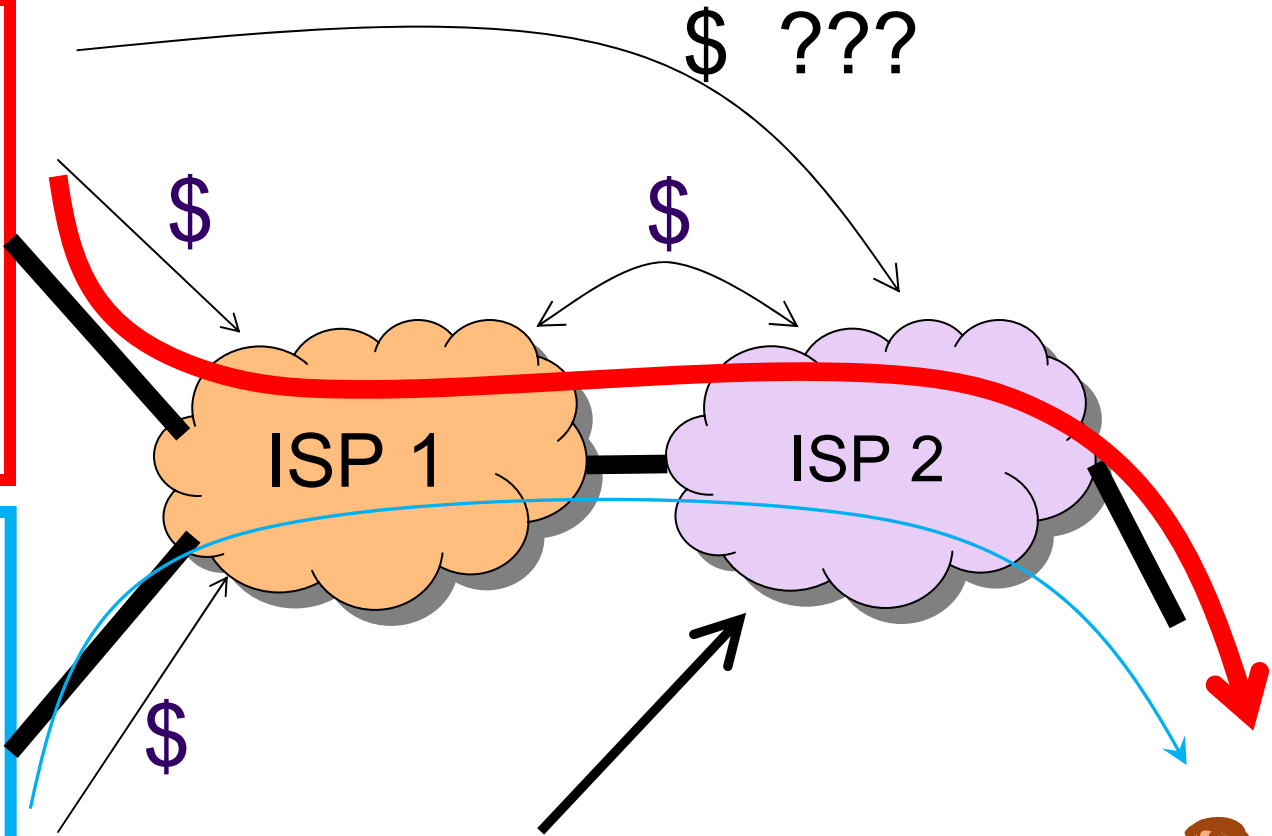

ISP 2 needs to invest
To enable A's service



Neutrality: Issues

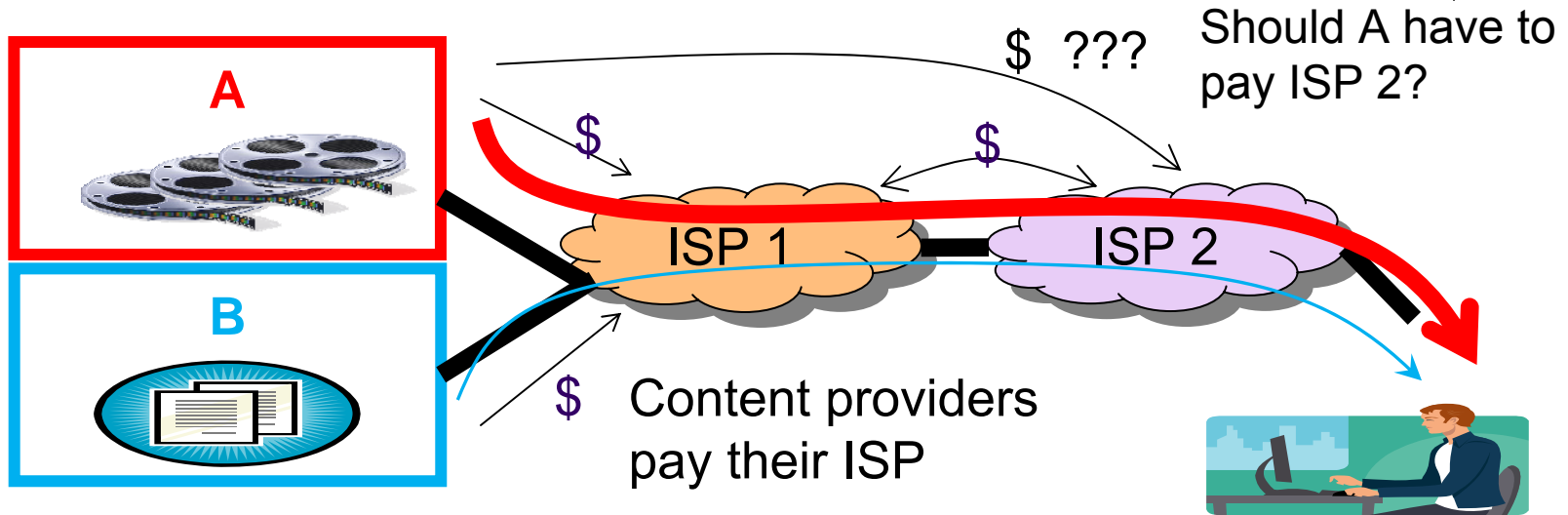

- Would allowing 2 to charge A
 - encourage 2 to invest?
 - discourage A to invest?
- What revenue sharing mechanisms should new Internet have?



Neutrality: Model

(Content Investment, ISP Investment) → Usage

Usage → (Ad Revenue to Content, User Revenue to ISPs)

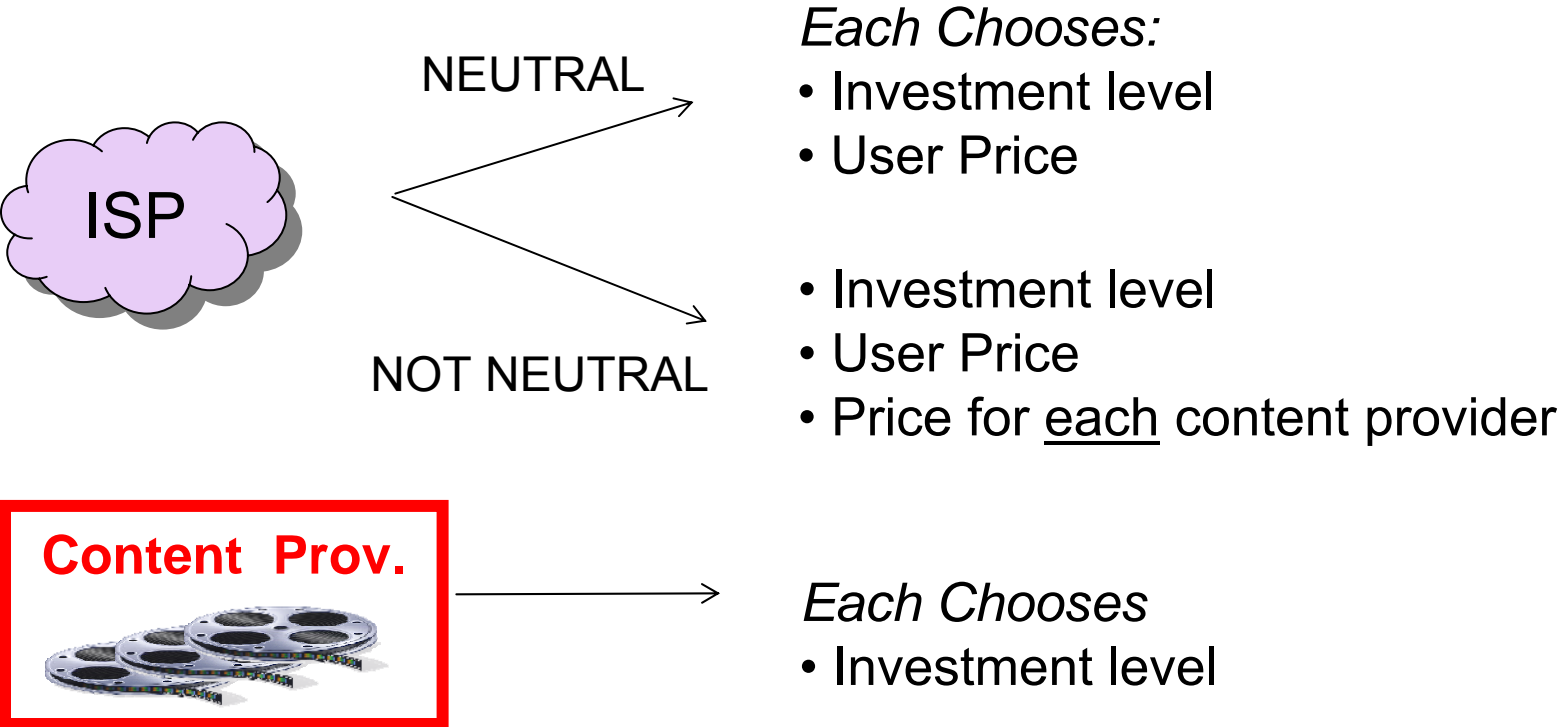

Neutrality: Model



Simple Model:

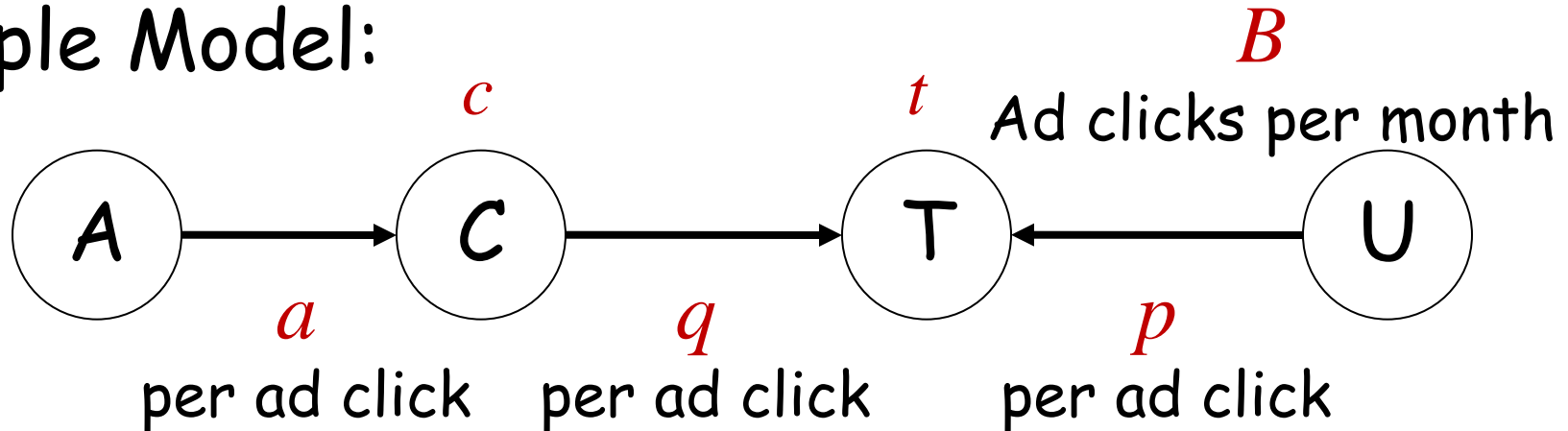

$$B = c^v t^w e^{-p/\theta} \quad 0 < v, w; v + w < 1$$

$$R_C = (a - q)B - \alpha c$$

$$R_T = (q + p)B - \beta t$$

A = advertisers
C = content provider
T = transport provider
U = regular users

Neutrality: Model



Simple Model:

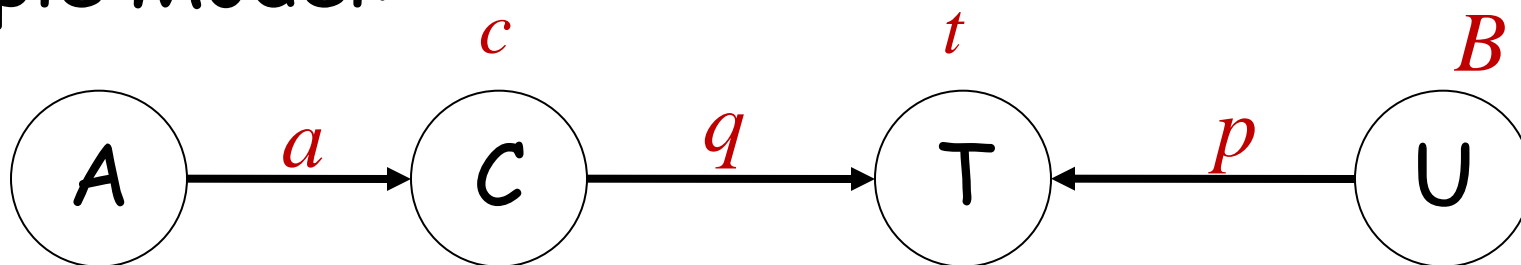

$$B = c^v t^w e^{-p/\theta} \quad 0 < v, w; v + w < 1$$

$$R_C = (a - q)B - \alpha c$$

$$R_T = (q + p)B - \beta t$$

Question:

$$q \uparrow \Rightarrow R_T \uparrow$$

or

$$q \uparrow \Rightarrow R_C \downarrow \Rightarrow c \downarrow \Rightarrow B \downarrow \Rightarrow R_T \downarrow$$

Neutrality: Model



Simple Model:

$$B = c^v t^w e^{-p/\theta} \quad 0 < v, w; v + w < 1$$

$$R_C = (a - q)B - \alpha c$$

$$R_T = (q + p)B - \beta t$$

Assume T chooses (t, p, q) . Then C chooses c to max

$$R_C = (a - q)c^c t^w e^{-p/\theta} - \alpha c$$

Given this $c(t, p, q)$, T then chooses (t, p, q) to max

$$R_B = (p + q)c^c t^w e^{-p/\theta} - \beta t$$

Neutrality: Model



Simple Model:

$$B = c^v t^w e^{-p/\theta} \quad 0 < v, w; v + w < 1$$

$$R_C = (a - q)B - \alpha c$$

$$R_T = (q + p)B - \beta t$$

In the neutral case, T chooses $(t, p, q = 0)$. Then C chooses c to max

$$R_C = a c^c t^w e^{-p/\theta} - \alpha c$$

Given this $c(t, p, 0)$, T then chooses $(t, p, 0)$ to max

$$R_B = p c^c t^w e^{-p/\theta} - \beta t$$

Neutrality: Results



Result 1:

The revenues per click and ROIs are the same under both regimes for content and transport providers.

Result 2:

The size of the market is larger in the neutral case only if a/θ is neither very large nor very small.

Neutrality: Results



$$\left(\frac{B(\text{neutral})}{B(\text{non-neutral})} \right)^{1-v-w}$$

$$\left(\frac{t(\text{neutral})}{t(\text{non-neutral})} \right)^{1-v-w}$$

$$\left(\frac{R_T(\text{neutral})}{R_T(\text{non-neutral})} \right)^{1-v-w}$$

$$\left(\frac{c(\text{neutral})}{c(\text{non-neutral})} \right)^{1-v-w}$$

$$\left(\frac{R_C(\text{neutral})}{R_C(\text{non-neutral})} \right)^{1-v-w}$$

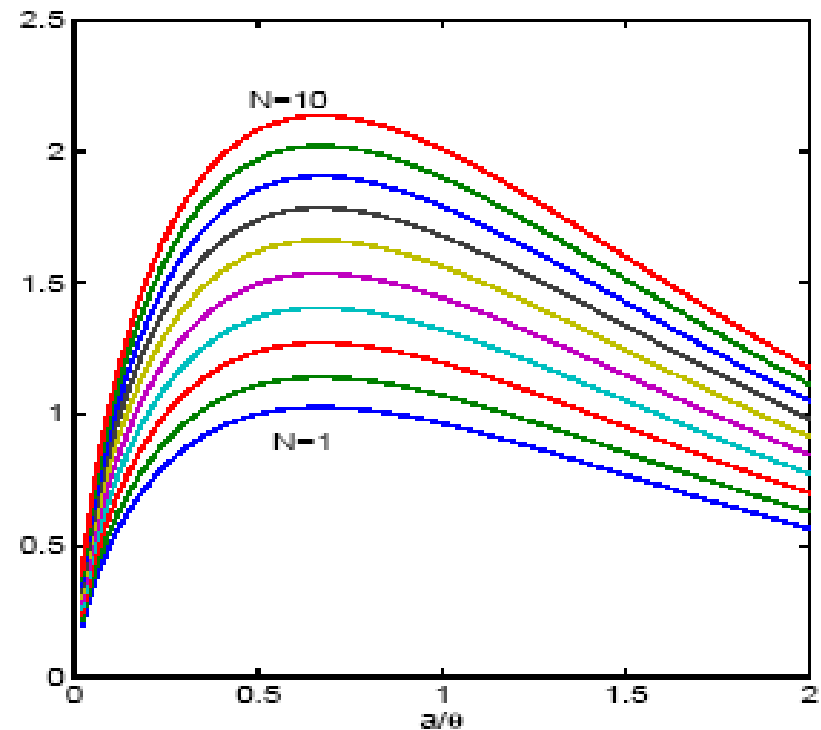
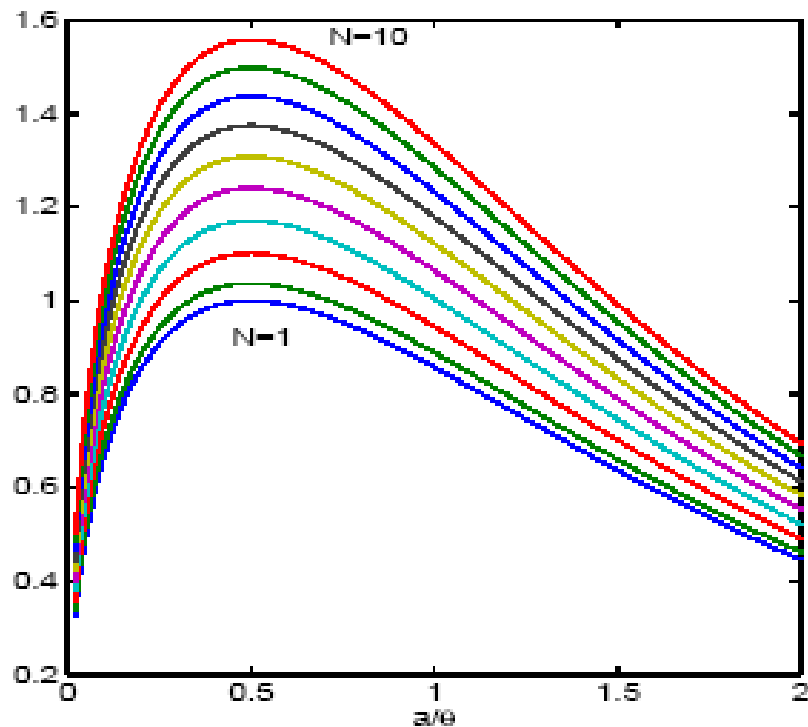

Neutrality: Results

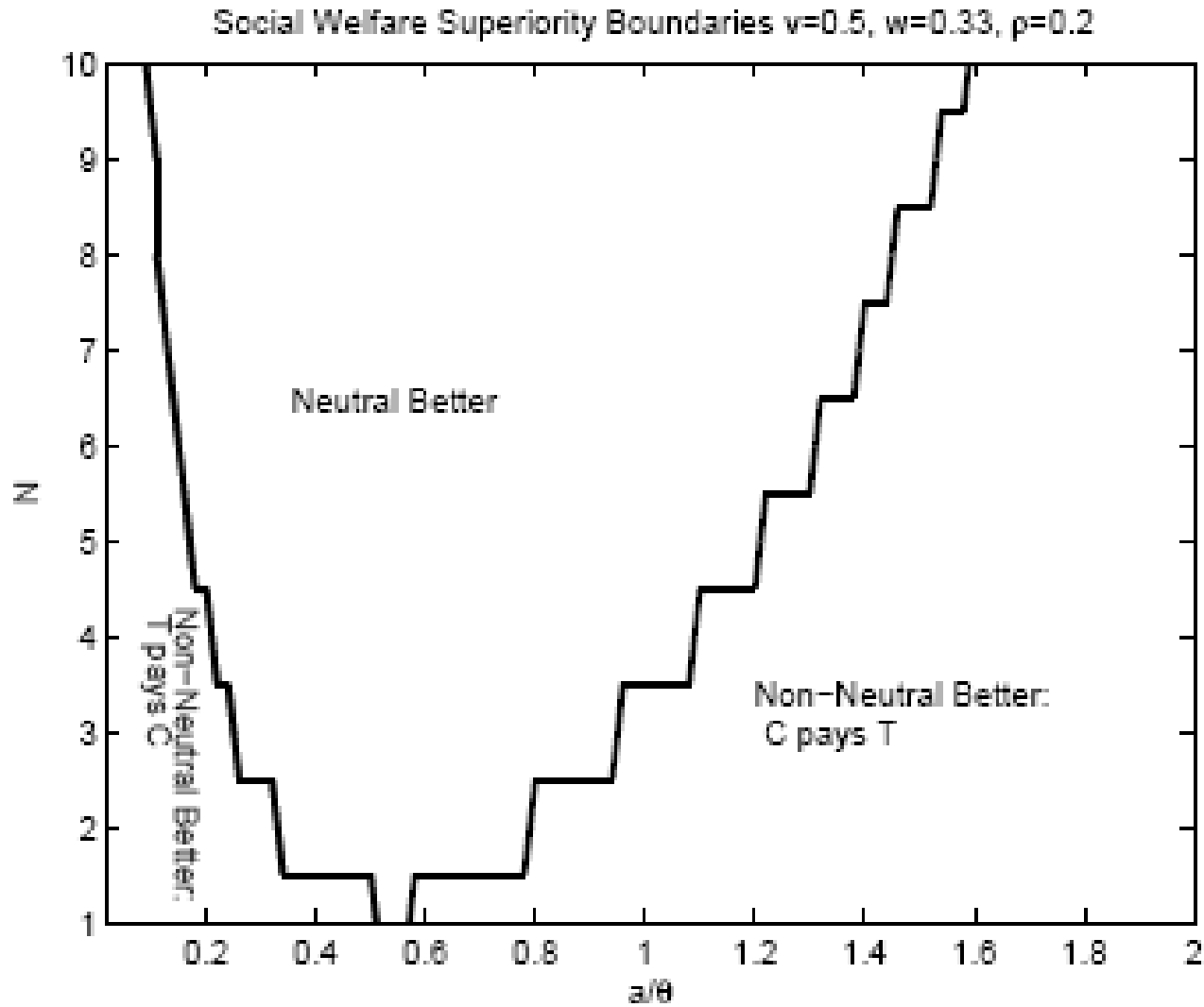

Pricing of Bandwidth and Communication on Demand Services



- Issues
- Users & Providers
- General Pricing
- Externality: Congestion Pricing
- Service Differentiation: Paris Metro Pricing
- Competition of Providers
- Pricing QoS
- Uncertainty
- One-Sided Auctions
- Net Neutrality
- References ←

References



Here is a list of some references I used to prepare the material..

- George Akerlof, [The Market for Lemons](#)
- PioBaake, ThorstenWichmann-**On the Economics of Internet Peering -January 1998.**
- Chiu D-M and Jain R (1989). **Analysis of the increase and decrease algorithms for congestion avoidance in computer networks.***Comp Networks and ISDN Sys* 17: 1±14.
- Courcoubetis, C and R.R. Weber(2003). **Pricing Network Services, Springer Verlag.**
- Cremer, J., P. Rey& J. Tirole,"**Connectivity in the Commercial Internet**" *Journal of Industrial Economics*, December 2000,vol48, n°4, pp. 433-472
- Feigenbaum, C. H. Papadimitriou, R. Sami, S. Shenker(2002) **A BGP-based Mechanism for Lowest-cost Routing,"in Proceedings of the 21st Symposium on Principles of Distributed Computing, ACM Press, New York, 2002, pp 173-182.**
- Fudenberg, D. and J. Tirole(1991). **Game Theory. MIT Press.**
- Geoff Huston-**Interconnection and Peering, November 2000.**
- Garrett Hardin, [The Tragedy of the Commons](#), 1968
- P. Honeyman, G. Schwartz, "Interdependence of Reliability and Security," Workshop on Economics of Information Security, CMU, June 2007
- ITS, [Congestion Pricing](#)
- J. Musacchio, S. Wu, "A Game Theoretic Model for Network Upgrade Decisions," Allerton Conference 2006.

References



- J. Musacchio, S. Wu, “ The Price of Anarchy in a Network Pricing Game,” in submission.
- Musacchio, J. and J. Walrand. **Game-theoretic analysis of Wi-Fi Access Pricing, in preparation.**
- J. Musacchio, J. Walrand, “Economic Consequences of Weak Network Neutrality,” to appear at Asilomar 2007.
- [Tim Roughgarden](#), [Selfish Routing and the Price of Anarchy](#)
- [Hal Varian](#), [System Reliability and Free Riding](#), 2001
- Y. Jin and G. Kesidis, **Feasible pricing of differentiated services for the emerging Internet, in Proc. 40th Allerton Conference on Communications, Control and Computing, Oct. 2002.**
- J.-J. Laffont, S. Marcus, P. Rey, and J. Tirole, “**Internet interconnection and the off-net-cost pricing principle,**” 2001.
- Andrew Odlyzko, **Paris Metro Pricing for the Internet(1998), ACM Conference on Electronic Commerce**
- [PG93] AbhayK. Parekh, Robert G. Gallager: **A Generalized Processor Sharing Approach to Flow Control in Integrated Services Networks: The Multiple Node Case. INFOCOM 1993: 521-530.**
- [S90] Vernon Smith et al., “**Auction Design for Composite Goods,**” **Journal of Economic Behavior and Organization, 14 (1990) 127-129.**
- [SV03] Jun Shu and PravinVaraiya, **Pricing Network Services. Infocom2003.**
- [V61] Vickrey, W., 1961, “**Counterspeculation, Auctions, and Competitive Sealed Tenders,**” **Journal of Finance, XVI, 8-37.**